

Cylinder pressure regulator FE53

spectro**cem**

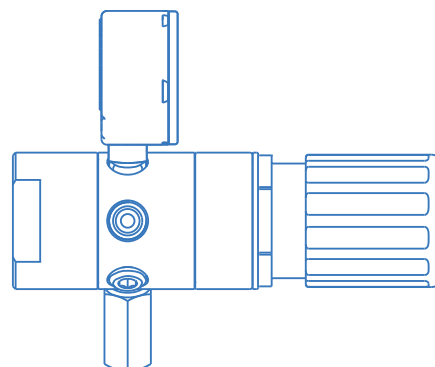

Cylinder pressure regulator FE53



Product features

- Double-stage stainless steel cylinder pressure regulator with extremely stable outlet pressure and anti-vibration device
- For corrosive, toxic gases and gas mixtures with corrosive components up to quality 6.0
- 6 ports for flexible and individual configuration
- New laboratory-style design
- Central filter
- Suitable for ECD-applications
- Pressure regulator can be evacuated
- Suitable for inlet pressures up to 300 bar
- Max. outlet pressures 1.5 up to 20 bar
- Light weight
- Compact design
- Approved for use with oxygen
- Simple outlet pressure limitation by handwheel
- Easy to install

Technical data

Type	double-stage
Inlet pressure P_1	max. 300 bar
Outlet pressure P_2	1,5 / 4 / 10 / 20 bar
Materials	
Body regulator, relief valve:	SS 316L (SS 1.4404)
Valve seat:	PVDF
Diaphragm:	Hastelloy C276
Filter:	Sintered SS 316L
In- and outlets	1/4" NPT-F
Temperature range	-30°C to +60°C
Leak rate (to atmosphere)	1×10^{-8} mbar l/s He
(via seat)	1×10^{-6} mbar l/s He
Pressure gauge	Safety pressure gauges ISO5171/KI1.6/NG50
Weight	1.8 kg

Flow curves FE53

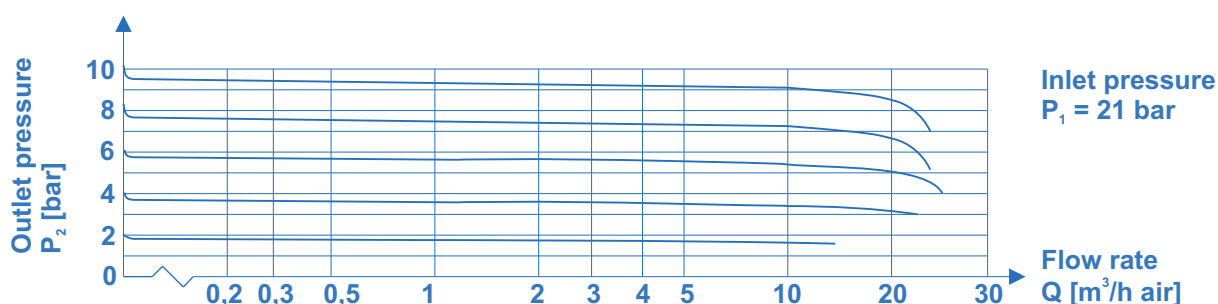

Cylinder pressure regulator FE53



Dimensions

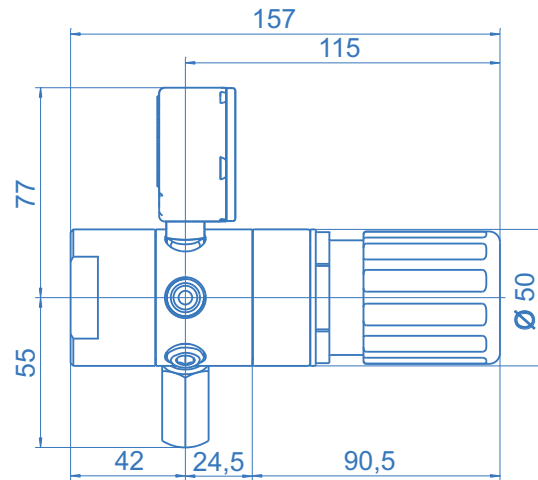
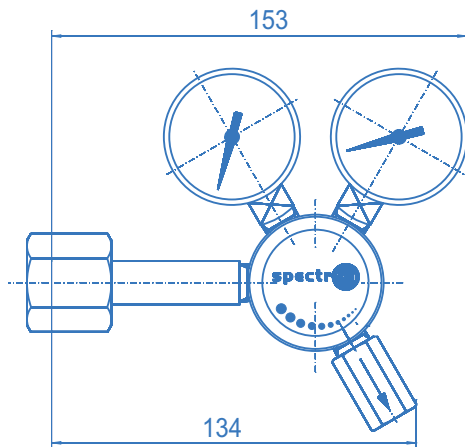

Ordering information: Cylinder regulator FE53

In- / outlets

- CE 1/4 - 1/8" / 1/4" / 1/2" - OD compression fitting (stainless steel)
- CE 6 - 3/6/8/10/12 mm OD compression fitting (stainless steel)
- B - plug
- A - relief valve - 1/4"-18 NPT-F ($P_2 \leq 100$ bar)
- xxxx - detailed specification of cylinder connection including the relevant standard and number (e.g. BS no.3 for nitrogen up to 230 bar)
- K - contact pressure gauge
- M - pressure gauge
- 0 - 1/4"-NPT-F (port only)

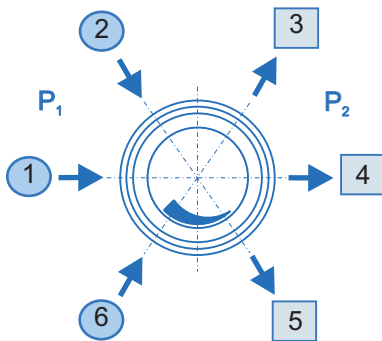

Inlet left: **L**

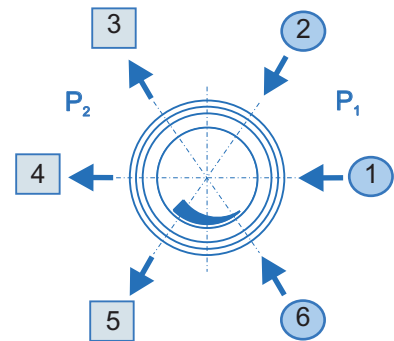

Inlet right: **R**

FE53 - L - 300 - 20 - 1 - 2 - 3 - 4 - 5 - 6 - N2

Inlet

- L - left
- R - right

Inlet pressure P_1

- 100 - max. 100 bar
- 200 - max. 200 bar
- 300 - max. 300 bar

Outlet pressure P_2

- 1,5 - bis 1,5 bar
- 4 - bis 4 bar
- 10 - bis 10 bar
- 20 - bis 20 bar

Type of gas

Please specify type of gas (for selection of valve seat materials)

For inlet pressure up to 50 bar and outlet pressure of max. 1,5 or 4 bar please use E51